

PLAN VIEW

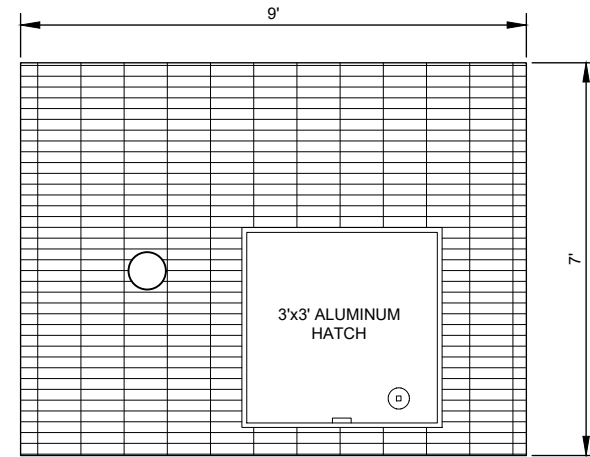

TOP SLAB

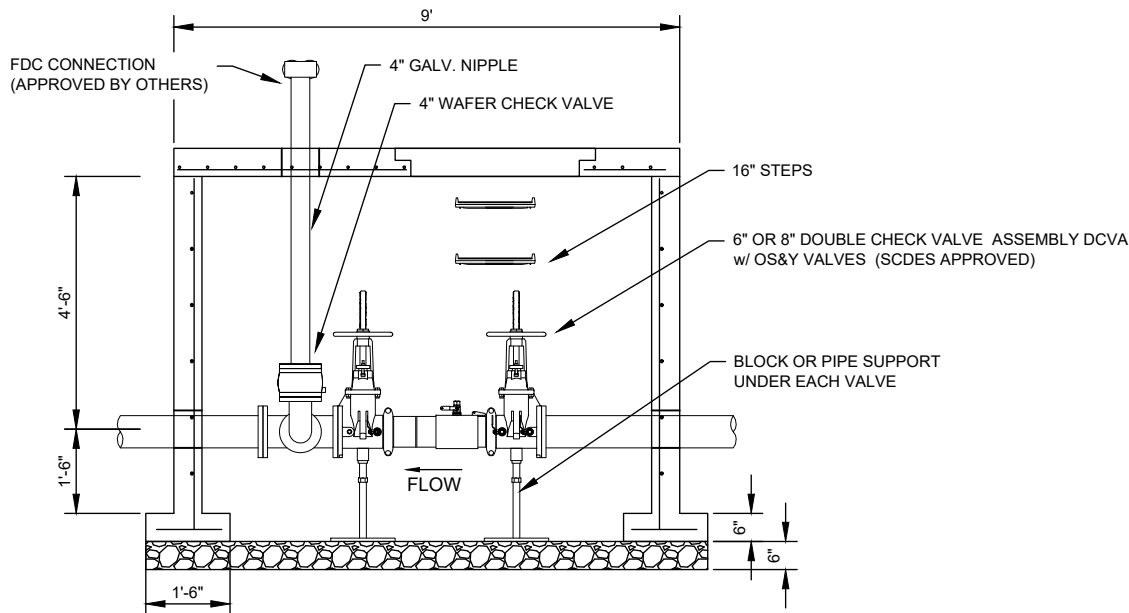

ELEVATION VIEW

GENERAL NOTES:

1. REINFORCEMENT:
 - a) WALLS - #4 GRADE 60 BAR @ 10" OCEW.
 - b) FOOTER & TOP - #5 GRADE 60 BAR @ 8" OCEW.
2. ALL HIGH HAZARD INSTALLATIONS REQUIRE AN RPZ INSTALLED IN AN ABOVE GROUND ENCLOSURE.
3. DOUBLE CHECK DETECTOR ASSEMBLY TO BE INSTALLED ON ALL FIRE SYSTEMS 4" AND LARGER.
4. AFTER INSTALLATION A FIELD TEST REPORT SHOULD BE COMPLETED AND EMAILED TO BFP@greenvillewater.com.



GreenvilleWater

6" & 8" - BACKFLOW PREVENTER VAULTS

REVISION DATE:

08.21.2025

(NOT TO SCALE)

DETAIL NO:

17.1