

COMMISSIONERS OF PUBLIC WORKS
OF THE CITY OF GREENVILLE
SOUTH CAROLINA

GREENVILLE WATER

CONSTRUCTION SPECIFICATIONS

FOR

WATER MAINS



Murray William Dodd
1/13/14

A circular professional seal for Murray William Dodd, a Registered Professional Engineer in South Carolina. The seal contains the text "SOUTH CAROLINA REGISTERED PROFESSIONAL ENGINEER" and "MURRAY WILLIAM DODD". The date "1/13/14" is stamped in the center.



[Signature]
No. 11248
1/13/14

A circular professional seal for Michael David Sharpless, a Registered Professional Engineer in South Carolina. The seal contains the text "SOUTH CAROLINA REGISTERED PROFESSIONAL ENGINEER" and "MICHAEL DAVID SHARPLESS". The number "No. 11248" and the date "1/13/14" are stamped in the center.

January 2014

TABLE OF CONTENTS

SPECIFICATIONS	<u>PAGE</u>
SECTION 1 South Carolina Department of Health and Environmental Control Requirements	3
SECTION 2 Trench Excavation and Backfilling	7
SECTION 3 Seeding and Sodding	13
SECTION 4 Installation of Ductile Iron Pipe and Appurtenances	17
SECTION 5 Material Specifications	23
FIGURES	Following Page 25
1 Pipe Embedments	
2 Typical Horizontal Thrust Block	
3 Typical Hydrant Installation	
4 2-Inch Blow-Off	
5 Air Release Valve	

SECTION 1

SOUTH CAROLINA DEPARTMENT OF HEALTH AND ENVIRONMENTAL CONTROL REQUIREMENTS

1-1. All material or products which come into contact with drinking water shall be third party certified as meeting the specifications of the American National Institute/National Sanitation Foundation Standard 61, Drinking Water System Components – Health Effects. The certifying party shall be accredited by the American National Standards Institute.

1-2. All pipe, fittings packing, jointing materials, valves and fire hydrants shall conform to Section C of the AWWA Standards.

1-3. Water mains which have been previously used for conveying potable water may be reused provided they meet applicable criteria from AWWA Section C, ANSI-NSF 61, and ASTM D1785 or D2241. The mains must be thoroughly cleaned and restored practically to their original condition.

1-4. Asbestos cement pipe shall not be used in potable water systems except in the repair of existing asbestos cement lines.

1-5. Thermoplastic pipe shall not be used above grade.

1-6. Materials shall meet the following:

- a. DIP: AWWA C150/A21.50 & AWWA C151/A21.51
- b. Steel: AWWA C200 or ASTM A53 or A120.
- c. Valves: AWWA C500 (Metal Seated Gate Valve), C504 (Butterfly Valve) or C509 (Resilient Seated Gate Valve).
- d. Hydrants: AWWA C502

1-7. Natural rubber or other material which will support microbiological growth may not be used for any gaskets, O-rings, and other products used for jointing pipes, setting meters or valves, or other appurtenances which will expose the material to the water.

1-8. Lubricants which will support microbiological growth shall not be used for slip-on joints.

1-9. The use of vegetable shortening is prohibited.

1-10. Any pipe, solder, or flux which is used in the installation or repair of any public water system, used in any plumbing which provides water through connection to a public water system, for human consumption, shall be lead free in accordance with the Reduction of Lead in Drinking Water Act. Lead free, for solder and flux, means those containing not more than 0.2 percent lead. Lead free means not more than a weighted average of 0.25 percent lead when used with respect to the wetted surfaces of pipes, pipe fittings, plumbing fittings and fixtures. Leaded joints necessary for the repair of CIP shall be exempt from the above.

1-11. No flushing device shall be directly connected to any sewer.

1-12. Air relief valves shall be provided in accordance with sound engineering practice at high points in water mains as required. Automatic air relief valves shall not be used in situations where flooding of the manhole or chamber may occur.

1-13. Chambers, pits or manholes containing valves, blow-offs, meters, air relief valves, or other such appurtenances to a distribution system, shall not be connected directly to any storm drain or sanitary sewer.

1-14. Installation of water mains and appurtenances shall be conducted in accordance with Section C of the AWWA Standards and/or manufacturer's recommended installation procedures.

1-15. Bedding:

- a. A continuous and uniform bedding shall be provided in the trench for all buried pipe.
- b. Backfill material shall be tamped in layers around the pipe and to a sufficient height above the pipe to adequately support and protect the pipe.
- c. Stones, other than crushed bedding, shall not come in contact with the pipe and shall not be within 6 inches of the pipe.

1-16. All water mains shall be provided with a minimum of 30 inches of cover, unless pipe material is steel, concrete, DIP, or other approved material, and if exposed should be insulated to prevent freezing.

1-17. All tees, bends, plugs and hydrants on lines 2.5 inches in diameter and larger shall be provided with reaction blocking, tie rods, or other approved method of restraint.

1-18. All water mains shall be detectable within 3 feet with electronic locating equipment.

1-19. Water mains shall be located out of contaminated areas, unless using pipe materials that will protect (i.e., DIP with chemical resistant gaskets). Re-route line if possible.

1-20. Separation of water mains and sewers:

- a. Parallel Installation: Water mains shall be laid at least 10 feet horizontally from any existing or proposed sewer. The distance shall be measured edge to edge. In cases where it is not practical to maintain a ten foot separation, the Department may allow deviation on a case-by-case basis, if supported by data from the design engineer. Such deviation may allow installation of the water main closer to a sewer, provided that the water main is laid in a separate trench or on an undisturbed earth shelf located on one side of the sewer at such an elevation that the bottom of the water main is at least 18 inches above the top of the sewer.

- b. Crossings: Water mains crossing sewers shall be laid to provide a minimum vertical separation of 18 inches between the outside of the water main and the outside of the sewer. This shall be the case whether the water main is either above or below the sewer line. Whenever possible, the water main shall be located above the sewer line. Where a new water main crosses a new sewer line, a full length of pipe shall be used for both the water main and sewer line and the crossing shall be arranged so that the joints of each line will be as far as possible from the point of crossing and each other. Where a new water main crosses an existing sewer line, one full length of water pipe shall be located so both joints will be as far from the sewer line as possible. Where a water main crosses under a sewer, adequate structural support shall be provided for the sewer line to prevent damage to the water main.
- c. Special Conditions: When it is impossible to obtain the distances specified by DHEC the Department may allow an alternative design. Any alternative design shall:
 - i. maximize the distances between the water main and sewer line and the joints of each;
 - ii. use materials which meet DHEC requirements for the sewer line; and,
 - iii. allow enough distance to make repairs to one of the lines without damaging the other.
- d. Force mains: There shall be at least a 10-foot horizontal separation between water mains and sanitary sewer force mains. There shall be an 18-inch vertical separation at crossing as required by DHEC.
- e. Sewer Manholes: No water pipe shall pass through or come in contact with any part of a sewer manhole. Water lines may come in contact with storm sewers or catch basins if there is no other practical alternative, provided that ductile iron is used, no joints of the water line are within the storm sewer or catch basin and the joints are located as far as possible from the storm sewer or catch basin.
- f. Drain-fields and Spray-fields: Potable water lines shall not be laid less than 25 feet horizontally from any portion of a waste-water tile-field or spray-field, or shall be otherwise protected by an acceptable method approved by the Department.

1-21. Above-water crossings: The pipe shall be adequately supported and anchored, protected from damage and freezing, accessible for repair or replacement.

1-22. Underwater crossings: A minimum of 2 feet of cover shall be provided over the pipe. When crossing water courses that are greater than 15 feet in width, the following shall be provided:

- a. The pipe material and joints shall be designed appropriately.

- b. Valves shall be located so the section can be isolated for testing or repair; the valves (on both sides of crossing) shall be easily accessible and not subject to flooding.
- c. A blow-off shall be provided on the side opposite the supply service sized in accordance with DHEC Standards. Direct away from streams, over ground.
- d. Use DIP with mechanical joints for any lines being installed in rock.

1-23. Cross Connection Control (Backflow Prevention Devices):

- a. There shall be no connection between the distribution system and any pipes, pumps, hydrants, or tanks whereby unsafe water or other contamination materials may be discharged or drawn into the system.
- b. No by-passes shall be allowed, unless the bypass is also equipped with an equal, approved back-flow prevention device.
- c. High hazard category cross connections shall require an air gap separation or an approved reduced pressure backflow preventer.
- d. Reduced pressure principal backflow prevention assemblies shall not be installed in any area location subject to possible flooding. This includes pits or vaults which are not provided with a gravity drain to the ground's surface that is capable of exceeding the discharge rate of the relief valve. Generally, if installed in a pit, the drain line shall be 2 times the size of the line entering the backflow prevention device. The drain cannot empty into any type of ditch, storm drain, or sewer, which could flood water back into the pit.
- e. All piping up to the inlet of the backflow prevention device must be suitable for potable water. The pipe must be AWWA or NSF approved. Black steel pipe cannot be used on the inlet side of the device.
- f. Fire line sprinkler systems and dedicated fire lines, except those in the high hazard category shall be protected by an approved double check valve assembly.

End of Section

SECTION 2

TRENCH EXCAVATION AND BACKFILLING

2-1. SCOPE. This specification covers excavation work required for, and in connection with, the performance of the work specified and contracted for in these documents and shall include the necessary site preparation; excavation and trenching as required; the handling, storage, transportation, and disposal of all excavated material; all necessary sheeting, shoring and protective work; sub grade preparation; pumping and dewatering as necessary or required; pipe embedment; protection of adjacent property and underground structures; backfilling; specified compaction and consolidation of the backfill; and other appurtenant work.

2-2. GENERAL REQUIREMENTS. Excavation work shall be performed in a safe and proper manner, with suitable precautions being taken against hazards of every kind. The contractor shall be responsible for safety and shall comply with all laws and regulations pertaining to safety. Excavations shall provide adequate working space and clearances for the work to be performed therein.

Subgrade surfaces shall be clean and free of loose material of any kind when concrete is placed thereon. Excavations shall provide adequate clearance for installation and removal of concrete forms. In no case shall excavation faces be undercut for extended footings. Except where the exterior surfaces thereof are specified to be waterproofed, monolithic concrete manholes, pipe encasements and other concrete structures, or parts thereof, may be poured directly against excavation faces without the use of outer forms, provided that such faces are stable, and also provided that a layer of polyethylene film is placed between the earth and the concrete.

Backfilling during freezing weather shall not be done except by permission of the Engineer. No frozen materials, snow or ice, shall be placed in any backfill.

2-3. CLASSIFICATION OF EXCAVATED MATERIALS. Classification of excavated materials will be made as follows:

- a. Earth excavation will include the removal and subsequent handling of all loose rock, gravel, or decomposed or disintegrated shale which in the opinion of the Engineer can be effectively removed with power driven excavating equipment of a type and size required for the normal excavation of the specified trench involved; also all vegetation, debris, junk broken concrete, brick, stones or boulders and other materials encountered within excavation limits except rock.
- b. Rock, as classified herein, is defined as being sandstone, limestone, flint, granite, quartzite, slate, hard shale, or similar material which requires blasting for its practical and effective removal. Should rock be encountered in two or more lengths, each ledge being not less than 3 inches in thickness and with interlaying strata of earth,

clay, or gravel not more than 12 inches thick in each stratum, the entire volume between the top of the top ledge and the bottom of the bottom ledge will be classified as rock.

2-4. BLASTING. The Contractor shall comply with all laws, ordinances, applicable safety code requirements, and regulations relative to the handling, storage, and use of explosives and the protection of life and property. He shall be responsible for all damage caused by his blasting operations.

Suitable weighted protective coverings shall be provided to confine all materials, lifted by blasting, within the limits of the excavation or trench.

All rock which cannot be handled and compacted as earth shall be kept separate from other excavated materials and shall not be mixed with other backfill or embankment materials except as specified or directed.

2-5. REMOVAL OF WATER. The Contractor shall provide and maintain adequate dewatering equipment to remove and dispose of all surface and ground water entering excavation, trenches, or other parts of the work. Each excavation shall be kept dry during subgrade preparation and continually thereafter until the structure to be built, or the pipe line to be installed, therein is completed to the extent that no damage from hydrostatic pressure, flotation, or other causes will result.

Surface water shall be diverted or otherwise prevented from entering excavated areas or trenches, to the greatest extent practicable without causing damage to adjacent property.

2-6. SHEETING AND SHORING. Except where banks are cut back on a stable slope, excavation for structures and trenches shall be properly and substantially sheeted, braced, and shored, as necessary, to prevent caving or sliding, to provide protection for workmen and the work, and to provide protection for existing structures and facilities. Sheeting, bracing, and shoring shall be designed and built to withstand all loads that might be caused by earth movement or pressure, and shall be rigid, maintaining its shape and position under all circumstances.

2-7. STABILIZATION. Trench bottoms and subgrades for concrete structures shall be firm, dense, and thoroughly compacted and consolidated; shall be free from mud and muck; and shall be sufficiently stable to remain firm and intact under the feet of the workmen.

Trench bottoms or subgrades for concrete structures which are otherwise solid, but which become mucky on top due to construction operations, shall be reinforced with one or more layers of crushed stone or gravel embedded therein. The finished elevation of stabilized subgrades shall not be above the subgrade elevations shown on the plans or specified herein.

2-8. TRENCH EXCAVATION.

2-8.01. General. The Contractor shall not open more trench in advance of pipe laying than is

necessary to expedite the work and, in the event that pipe laying is stopped for any cause, 200 feet shall be the maximum length of open trench allowed on any section of the line under construction.

Under ordinary conditions, excavations shall be by open cut from the surface. Where the depth of trench and soil conditions permit, tunneling or boring may be required beneath cross walks, concrete driveways, curbs, gutters, pavements and other surface structures. For such tunneling or boring, no additional compensation will be allowed over the bid price based upon open cut excavation of equivalent depths below the ground surface.

Where indicated on the drawings, tunneling or boring shall be provided. For such tunneling or boring, compensation shall be made in accordance with the bid form.

2-8.02. Minimum Cover. Where pipe grades or elevations are not definitely fixed by the contract drawings, trenches shall be excavated to a depth sufficient to provide a minimum depth of backfill cover over the top of the pipe of 30-inches for galvanized steel pipe and 36 inches for ductile iron pipe.

2-8.03. Limiting Trench Widths and Pipe Clearances. Trenches shall be excavated to a width which will provide adequate working space and pipe clearances for proper pipe installation, jointing, and embedment. However, the limiting trench widths below an elevation 6 inches above the top of the installed pipe, and minimum permissible clearances between the installed pipe and either trench wall, shall be as follows.

<u>Size of Pipe</u> (inches)	<u>Minimum Clearance</u> (inches)
6 through 20	8
24 through 36	9
42	18
48	21
54	24
60 through 64	27

The stipulated minimum clearances are not minimum average clearance, but are minimum clear distances which will be permitted between any part of the pipe as laid and any part, projection or point of rock, shale, stone, or boulder.

When necessary to reduce the earth load on trench banks to prevent sliding and caving, the banks may be cut back on slopes which shall not extend lower than one foot above the top of the pipe.

2-8.04. Excavation Below Pipe Subgrade. Except where otherwise required, pipe trenches shall be excavated below pipe subgrade elevations, as shown on Figure 1, to provide for the installation of pipe foundation material as specified under "PIPE EMBEDMENT."

2-8.05. Bell Holes. Bell holes shall provide adequate clearance for the tools and methods used

in installing the pipe. No part of any bell or coupling shall be in contact with the trench bottom, trench walls, or the bedding material when the pipe is jointed.

2-9. PIPE EMBEDMENT. Embedment materials, both below and above the bottom of the pipe; the classes of embedment to be used; and the placement and compaction of embedment materials shall conform to the requirements shown on Figure 1 "Pipe Embedments," and to the following supplementary requirements.

2-9.01. Embedment Classes.

- a. Class A Arch encasement shall be used where trench conditions dictate their use as determined by the Engineer.
- b. Class B bedding, consisting of the specified granular material shall be used where such embedment is shown on the drawings or where conditions dictate its use as determined by the Engineer.
- c. Class C bedding, consisting of the specified granular material shall be used where such embedment is shown on the drawings or where conditions dictate its use as determined by the Engineer.
- d. Class D bedding, consisting of select job excavated material (being non-cohesive, finely divided soil, free of debris, stones, rock excavation detritus, organic materials or other objectionable material and having a moisture content which will insure proper pipe embedment) shall be used for all pipe lines unless otherwise indicated on the drawings.

2-9.02. Placement and Compaction. The approved embedment material shall be spread, and the surface graded to provide a uniform and continuous support, beneath the pipe at all points between bell holes or pipe joints. It will be permissible to slightly disturb the finished subgrade surface by the withdrawal of pipe slings or other lifting tackle.

After each pipe has been graded, aligned, and placed in final position on the bedding material and shoved home, sufficient pipe embedment materials shall be deposited and compacted under and around each side of the pipe and back of the bell or end thereof to firmly hold and maintain the pipe in proper position and alignment during subsequent pipe jointing, embedment, and backfilling operations.

Embedment material shall be deposited and compacted uniformly and simultaneously on each side of the pipe to prevent lateral displacement of the pipe.

Tamped backfill embedment materials shall be placed uniform layers and shall have a moisture content which will insure that the maximum density will be obtained with the compaction method used.

2-10. TRENCH BACKFILL. All trench backfill above pipe embedment shall conform to the following requirements.

2-10.01. Tamped Backfill. Tamped backfill will be required for the full depth of the trench above the pipe embedment in the following locations:

- a. Where beneath pavements, surfacing, driveways, curbs, gutters, walks, or other surface construction or structures.
- b. Where in street, road, or highway shoulders that are maintained by governmental agencies requiring such backfill compaction.

Material for tamped backfill and the method of placement and compaction shall be as specified for tamped backfill for pipe embedment.

2-10.02 Uncompacted Backfill. Compaction of trench backfill above pipe embedments in locations other than those hereinbefore specified will not be required.

Uncompacted earth backfill material which is to be placed above embedments shall be free of brush, roots more than 2 inches in diameter, debris, and junk, but may contain rubble and detritus from rock excavation, stones, and boulders, in certain portions of the trench depth with the specific approval of the Engineer.

Uncompacted backfill material above embedments may be placed by any method or combination of methods, approved by the Engineer, which will not impose excessive concentrated or unbalanced loads, shock, or impact on, and which will not result in displacement of, the installed pipe.

Compact masses of stiff mucky clay, or gumbo, or other consolidated material more than one cubic foot in volume shall not be permitted to fall into the trench unless cushioned by at least 2 feet of loose backfill above the pipe embedment.

No hard rock, stone or boulder larger than 8 inches in its greatest dimension shall be placed within 3 feet of the top of pipe. Large stones may be placed in the remainder of the trench backfill only if well separated and so arranged that no interference with backfill settlement will result.

2.11. CUTTING AND RESTORING PAVEMENT AND WALKS. Pavement may be cut only where, in the manner, and to the extent specified herein, shown on the plans or authorized by the Engineer. Cuts shall be no larger than necessary to provide adequate working space for proper installation of pipe and pipe line appurtenances, as determined by the Engineer.

2-11.01. Concrete Pavement, and concrete base pavement, over trenches excavated for pipe lines shall be removed to a width 24 inches wider than the width of the trench at the pavement subgrade. The trench width at the trench bottom shall not be greater than at the top, and no under-cutting will be permitted. A shoulder not less than 12 inches in width at any point shall be

left between the cut edge of the pavement and the top edge of the trench. Pavement cuts shall be straight and parallel.

Concrete walks may be cut and replaced where the alignment of the pipe crosses perpendicular to such walk. Where the alignment of the pipe is beneath and parallel to existing walks the entire walk shall be removed and replaced.

2-11.02. Asphalt Pavement removed in the trenching operations shall be replaced, or patched, in accordance with the requirements, and subject to the control, of the authority owning, or having jurisdiction over and control of, such facilities in each case.

2-12. CLEANING UP. After the backfilling has been finished, grading and surfacing of the work areas shall be completed to the satisfaction of the Engineer. All excess excavated materials together with all debris, junk, stones, logs, stumps, roots, and other unsuitable materials shall be removed from the site and disposed of by, and at the expense of, the Contractor.

2-13. BASIS OF PAYMENT. All work performed under this specification shall be considered a subsidiary obligation of the Contractor with the exception of those items of work specifically identified on the bid form.

End of Section

SECTION 3

SEEDING AND SODDING

3-1. SCOPE. This section covers seeding and sodding to be performed after backfilling and final grading are complete.

All lawn, ditch, and street shoulder areas within street right-of-way and temporary construction easements that are damaged during the Work shall be restored, after completion of construction, to the complete satisfaction of Owner. All areas disturbed by Contractor outside the temporary construction easements shall be restored, at Contractor's expense, to the satisfaction of the property owner.

3-2. GENERAL. Sodding shall be required in established lawn areas. In addition, sodding shall be required where seeding will not remain due to washing.

Seeding and sodding shall be of the type and quality as acceptable to the property owner.

3-3. GUARANTEE.

3-3.01. Seeding. Contractor shall guarantee a uniform stand of seeding, free of weeds to the extent practical, and acceptable to Owner.

3-3.02. Sodding. Contractor shall guarantee the sodding Work to the extent that all transplanted sod shall be uniform in color, leaf texture, shoot density, and reasonably free of visible imperfections at acceptance.

3-4. MATERIALS.

3-4.01. Starter Fertilizer. Fertilizer shall be a complete pelleted or granulated fertilizer. The analysis in percent by weight shall be as follows, unless other recommendations are made by the soil testing laboratory:

Nitrogen	10%
Phosphorus	10%
Potassium	10%

3-4.02. Seed. The seed species shall be fescue and the mixture shall be fescue, ryegrass and bermuda.

3-4.03. Sod. Sod shall have been planted on cultivated agricultural land and grown specifically for sod purposes and shall conform to the quality standards of Nursery Grown Sod as defined by the Turfgrass Producers International. Sod shall be free of objectionable grassy and broad leaf weeds. The sod species shall be of the type and quality as to be acceptable to the property owner.

3-4.04. pH Adjustment. If laboratory soil testing indicates the need for increased soil pH the Contractor shall add agricultural lime as a soil amendment. Addition rates shall be determined by analysis of soil samples subjected to laboratory testing. Addition rates shall be as recommended by state Extension Service guidelines and/or local horticultural agencies.

3-4.05. Topsoil. Topsoil shall be fertile, natural soil, typical of the locality, free from stones, roots, sticks, clay, peat, weeds, and sod, and obtained from naturally well drained areas. It shall not be excessively acidic or alkaline nor contain toxic material harmful to plant growth. Stockpiled topsoil may be used but the Contractor shall furnish additional topsoil at his own expense if required.

3-4.06. Mulch. Mulch shall be a specially processed cellulose fiber containing no growth or germination inhibiting factors, or shall consist of straw from hay and shall include a tackifier. Mulch for hydroseeding operation shall be a wood mulch or combination wood and paper mulch.

3-5. PREPARATION

3-5.01. Clearing Prior to finish grading, areas to be seeded or sodded shall be cleared to remove stumps, stones, roots, cable, wire, debris or other materials that might hinder seeding or sodding and future turf maintenance.

3-5.02. Finish Grading. Seeding or sodding shall not be started until all earthwork has been substantially completed. Backfills and fills shall be allowed to settle, the topsoil spread, and finish grading completed before the Work is started. Finish grading shall result in a surface conforming to the contours indicated on the Drawings.

3-5.03. Application of Fertilizer and pH Adjustment. After finish grading, any fertilizer or chemicals for pH adjustment specified shall be applied uniformly to areas to be seeded.

Fertilizer application rate shall be 1,000 lbs/acre. Chemicals for pH adjustment shall be applied at a rate based on a soil test for pH. The rate shall be adequate to neutralize the soil.

3-5.04 Final Preparation Following application of additives and fertilizers the areas to be seeded or sodded shall be tilled to a true depth of 4 inches by disking, harrowing, or other accepted methods to thoroughly incorporate the additives and fertilizer, destroy vegetation, and pulverize the soil. After tilling, the bed shall be smoothed by dragging or floating. The surface shall be cleared of all stones, stumps, roots, wire, grade stakes, and other objects that might hinder future turf maintenance operations.

3-6. SEEDING.

3-6.01 Seed Application. Seed shall be applied within 72 hours after preparation of the seedbed. Seed shall be applied with equipment designed to give uniform application. Any method or combination of methods which uniformly distributes the seed directly in contact with the soil, covers the seed, and firms the bed, may be selected. Seed shall be placed approximately 1/4 inch below the surface at a rate of 100 lbs/acre.

3-6.02. Mulching. All seeded areas shall be mulched within 24 hours following seed application. Mulch shall be placed at a rate of 1-1/2 tons/acre.

3-7. HYDROSEEDING.

3-7.01. Seed Application. Seed shall be applied within 72 hours after preparation of the seedbed. The wood cellulose fiber mulch shall be applied at the minimum rate of 1,500 lb/acre in two separate operations. Ten percent of the specified rate of fiber mulch shall be applied with the seed and the remainder applied after seeding.

3-8. SODDING.

3-8.01. Application of Sod. Sod shall be placed within 72 hours after preparation of the sod bed.

Sod shall be cut and moved only when the soil moisture conditions are such that favorable results can be expected. When the soil is too dry, the sod shall be cut only after Contractor has watered the sod sufficiently to moisten the soil to the depth at which the sod is to be cut.

Care shall be exercised at all times to retain the native soil on the roots of the sod during the process of stripping, transporting, and planting. Dumping from vehicles will not be permitted.

The sod shall be transplanted within 24 hours from the time of stripping, unless stored in a satisfactory manner. During delivery and while in stacks, the sod shall be kept moist and shall be protected from exposure to the air and sun.

Sod shall be laid smoothly, edge-to-edge, and with staggered joints. The sod shall be immediately pressed firmly into contact with the sod bed by tamping or rolling with acceptable equipment so as to eliminate all air pockets, provide a true and even surface, and assure knitting.

Staking is not required, except in ditch flow lines; however, Contractor will be responsible for replacing all sod that is displaced by erosion during the maintenance period. Only wooden (lath) stakes shall be used.

3-9. WATERING.

3-9.01. Sodded Areas. Contractor shall provide all water, labor, and equipment for watering sodded areas. Sodded areas representing one day's planting shall be watered sufficiently to wet the sod pads and at least 2 inches of the sod bed. Thereafter, in the absence of adequate rainfall, watering shall be performed daily and as often as necessary to keep the sod pads moist at all times. Watering of sod shall continue as needed until final acceptance.

3-10. REPLANTING.

3-10.01. Seeded Areas. Unacceptably seeded areas shall be overseeded or completely reseeded as instructed by Engineer.

3-10.02. Sodded Areas. Prior to acceptance, sodded areas that show signs of substantial desiccation as evident by a loss of color and a distinct yellowing shall be resodded and shall continue to be resodded until an acceptable sod cover is obtained. Replanting operations shall be as specified except that fertilizer and lime shall be deleted from the operation.

3-11. MAINTENANCE. All areas shall be maintained until final acceptance of the project.

3-11.01. Seeded Areas. Maintenance shall include any necessary reseeding, repair of erosion damage, and replacement of displaced mulch until covered with seedlings. In the event erosion occurs from either watering operations or rainfall, such damage shall be repaired.

3-11.02. Sodded Areas. Original grades of the sodded areas shall be maintained after commencement of planting operations and until acceptance. Any damage to the finished surface shall be repaired. In the event erosion occurs from either watering operations or rainfall, such damage shall be repaired. Ruts, ridges, tracks, and other surface irregularities shall be corrected and areas resodded.

End of Section

SECTION 4

INSTALLATION OF DUCTILE IRON PIPE AND APPURTENANCES

4-1. HANDLING DUCTILE IRON PIPE AND FITTINGS. Pipe, fittings, valves, hydrants and accessories shall be handled in such a manner to insure installation in the work in sound, undamaged condition and conforming in all respects to specified requirements. Particular care shall be taken not to injure the coatings and linings of pipe and fittings.

Equipment, tools, and methods used in unloading, reloading, hauling and laying pipe and fittings shall be such that no damage is done thereto or the cement lining therein. Hooks used for insertion in ends of pipe shall have broad, well padded contact surfaces and shall be of such design and length that they will provide uniform support for a distance back from the end of the pipe of not less than one-third of the internal pipe diameter.

Pipe and fittings in which the cement lining has been broken or loosened shall be replaced by and at the expense of the Contractor. Where the damaged areas are small and readily accessible, the Contractor may be permitted to repair the lining, subject to the approval of the Engineer.

All pipe coating which has been damaged shall be repaired by the Contractor before installing the pipe.

4-2. CUTTING PIPE. Cutting of ductile iron pipe shall be done in a neat manner, without damage to the pipe or to the cement lining therein. Pipe cuts shall be smooth, straight, and at right angles to the pipe axis. All cutting of pipe shall be done with mechanical pipe cutters of an approved type.

4-3. CLEANING. The interior of all pipe and fittings shall be thoroughly cleaned of all foreign matter before being installed and shall be kept clean until the work has been accepted. All lumps, blisters, and excess coating shall be removed from exterior spigot and interior bell surfaces. Such surfaces shall be wire brushed and wiped clean and dry and free from oil and grease before placing the spigot in the bell. All joint contact surfaces shall be kept clean until the jointing is completed.

Every precaution shall be taken to prevent foreign material from entering the pipe while it is being installed. No debris, tools, clothing, or other materials shall be placed in the pipe.

Whenever pipe laying is stopped, the open end of the line shall be sealed with a watertight plug. All water that may have entered the trench shall be removed prior to removing the plug. It is essential that no mud, trench water, or other foreign matter be permitted to enter the pipe line at any time.

4-4. INSPECTION. During installation, while suspended and hanging free, each pipe and fitting shall be inspected for defects and rung with a light hammer to detect cracks. All defective, damaged, or unsound pipe and fittings shall be rejected and removed from the site of the work.

4-5. ALIGNMENT. All pipe shall be installed to the grade and alignment indicated by the drawings and as established by line and grade stakes, laser beam equipment or surveying

instruments, or as otherwise determined, fixed, or approved by the Engineer. Pipe lines or runs intended to be straight shall be laid straight. Deflections from a straight line or grade shall not exceed the values stipulated in Table 4 of AWWA C600. Either shorter pipe sections, or special bends shall be installed where the alignment or grade requires them.

4-6. PUSH ON TYPE JOINTS. After a length of pipe has been laid on the previously prepared pipe subgrade, with the spigot end close to the bell of the previously installed pipe, all interior bell and exterior spigot surfaces of the joint to be made shall be thoroughly cleaned, the rubber gasket installed in the gasket groove in the joint socket, and all joint surfaces well lubricated with a heavy vegetable soap solution. The pipe shall then be pulled or pushed into final position and to the full depth of the joint socket, by means of suitable jacks, tackle, or power driven equipment.

All instructions and recommendations of the pipe manufacturer, relative to gasket installation and other jointing operations, shall be observed and followed by the Contractor.

It is essential that each gasket is in proper position when the pipe is shoved "home" in order that a tight joint be secured, and care shall be taken when installing the gasket to see that it will not be displaced during jointing operations. A leaking joint will be in evidence of an improperly made joint. Each defective joint, if any, discovered after the pipe has been laid shall be repaired by and at the expense of the Contractor by a method acceptable to and approved by the Engineer.

4-7. MECHANICAL JOINTS. Mechanical joints shall be carefully assembled in accordance with the manufacturer's recommendations. If effective sealing is not obtained, the joint shall be disassembled, thoroughly cleaned and reassembled. Over tightening bolts to compensate for poor installation practice will not be permitted.

4-8. FLANGED JOINTS. When bolting flanged joints, care shall be taken to insure that there is no restraint on the opposite end of the pipe or fitting which would prevent uniform gasket compression or which would cause unnecessary stress in the flanges. One flange shall be free to move in any direction while the flange bolts are being tightened. Bell and spigot joints shall not be packed or assembled until all flanged joints affected thereby have been tightened. Bolts shall be tightened gradually and at a uniform rate, in such a manner that gasket compression is uniform over the entire area of the gasket.

4-9. CONNECTIONS WITH EXISTING PIPE LINES. Where connections are made between new work and existing piping, such connections shall be made as shown on the drawings, using suitable and proper fittings to suit the conditions encountered.

Each connection with an existing water pipe shall be made at a time and under conditions which will least interfere with service to customers affected thereby, and as authorized by the Owner. Suitable facilities shall be provided for proper dewatering, drainage, and disposal of all water removed from the dewatered lines and excavations, without damage to adjacent property.

Great care shall be taken to prevent pipeline contamination when dewatering, and making connections with, existing pipelines used for the conveyance or distribution of water for public use. No trench water, mud, or other contaminating substances shall be permitted to get into the

connected line or lines at any time during the progress of the work. The interiors of all pipe, fittings, and valves, both new and re-used, installed in such connections, shall be thoroughly cleaned and then swabbed with, or dipped in, strong chlorine solution having a chlorine content of 200 parts per million.

4-10. SETTING VALVES AND FITTINGS. Valves, plugs and other fittings shall be installed in the manner herein specified for cleaning, laying and jointing pipe and shall be located as shown on the drawings or as directed by the Engineer.

Each valve shall be inspected before installation to insure that all foreign substances have been removed from within the valve body, and shall be opened and closed to see that all parts are in first-class working condition. Geared valves shall be inspected to see that the gears are properly lubricated.

Each valve which is installed in direct contact with earth backfill shall be provided with a valve box of such type and design that surface loads, impact or shock will not be transmitted through the box to the valve.

Valves and valve boxes shall be set plumb. Each valve box shall be placed directly over the valve it serves, with the top of the box brought flush with the finished grade. After being placed in proper position, earth shall be filled in around each valve box and thoroughly tamped for a distance on each side of the box of 4 feet at top of the trench.

Blow-offs and air release valves shall be provided with gate valves or ball valves and shall be located and installed as shown on the plans. All dead ends shall be provided with a blow-off as shown.

4-11. SETTING HYDRANTS. Hydrants shall be located as shown on the drawings, or as directed by the Engineer, and shall be connected to the main with a 6-inch ductile iron branch controlled by an independent gate valve located as close to the supplying main as practical.

All hydrants shall stand plumb; shall be set to established grade with ground flanges slightly above, but not more than 6 inches above, the finished ground elevation; and shall be provided with suitable reaction blocking, bracing or joint harness to prevent any movement caused by internal water pressure. See Figure 2 - Typical Hydrant Installation.

In pervious soil, hydrant drainage shall be provided at its base by placing coarse gravel or graded crushed stone from the bottom of the trench to at least 6-inches above the waste opening in the hydrant and to a distance of 1-foot around the elbow except at the back where blocking occurs. Hydrant drains shall not be connected to or located within 10 feet of sewer systems. Thrust blocking should not block weep holes. Wherever a hydrant is set in clay or other impervious soil, a drainage pit 2 feet in diameter and 3 feet deep shall be excavated below each such hydrant and filled with coarse gravel or screened crushed stone.

4-12. REACTION ANCHORAGE AND BLOCKING. All tees and bends shall be provided with suitable reaction blocking, struts, anchors, clamps, joint harness, or other adequate means for

preventing any movement of the pipe caused by unbalanced internal water pressure. For sizing guideline, see Figure 3 - Typical Horizontal Thrust Block.

4-12.01. Trench Installation. Where in trench, the fittings shall be provided with concrete thrust blocking between the fitting and solid, undisturbed ground, except where solid ground blocking support is not available. Such reaction or thrust backing shall consist of concrete installed in such a manner that all joints between pipe and fittings are accessible for repair or replacement.

At the tops of slopes vertical angle bends shall be anchored by means of steel strap or rod anchors securely embedded in or attached to a mass of concrete of sufficient weight to resist the hydraulic thrust at the maximum pressures to which the pipe will be subjected. Bends at the base of slopes shall be provided with adequate concrete embedment to resist similar thrust.

The bearing area of concrete reaction blocking against the ground or trench bank shall be as shown by the plans or as directed by the Engineer in each case. In the event that adequate support against undisturbed ground cannot be obtained, metal harness anchorages consisting of steel rods or bolts across the joint and securely anchored to pipe and fittings or other adequate anchorage facilities approved by the Engineer shall be installed to provide the necessary support. Should the lack of a solid vertical excavation face be due to careless or otherwise improper trench excavation, the entire cost of furnishing and installing metal harness anchorages in excess of the contract value of the concrete blocking replaced by such anchorages shall be borne by the Contractor.

4-12.02. For Other Locations. Reaction blocking, struts, anchorages, or other supports for fittings installed in fills or other unstable ground, above grade, or exposed within structures, shall be provided as required by the plans or as directed by the Engineer.

4-13. PROTECTION OF METAL SURFACES. All steel clamps, rods, bolts and other metal accessories used in reaction anchorages or joint harness subject to submergence or contact with earth or other fill material and not encased in concrete shall be adequately protected from corrosion with not less than two coats of Carboline "Bitumastic 50" or Tnemec "46-465 H.B. Tnemecol," or approved equal, medium consistency coal tar coating material, applied to clean, dry metal surfaces. The first coat shall be dry and hard before the second coat is applied. Metal surfaces exposed above grade or within structures shall be painted with two coats (in addition to a primer coat) of a paint approved by the Engineer.

4-14. LEAKAGE. It is the intent of this specification that (a) all joints shall be watertight and free from visible leaks, and (b) each leak which may be discovered, at any time prior to the expiration of one year after the date of final acceptance of the work by the Owner, shall be repaired promptly by and at the expense of the Contractor.

4-15. PRESSURE TESTS. Pressure and leakage tests must be conducted in accordance with AWWA Standards C600. The duration of the pressure and leakage test must be at least two (2) hours. The formulas to be used for calculating the allowable leakage per hour shall be:

$$L = [SD(P)^{1/2}] \div 133,200$$

L-allowable leakage (gal/hr)
S-length of pipeline to be tested (feet)
D-diameter of pipe(inches)
P-average test pressure(psig)

All visible leaks shall be repaired regardless of the amount of leakage.

All ductile iron piping or pipe lines which are designed to operate under a working pressure of or in excess of 40 psi shall be subjected to a hydrostatic pressure test as hereinafter specified. Unless otherwise authorized by the Engineer, pressure tests of underground or otherwise concealed piping shall be made prior to covering the pipe joints.

The test pressure to be applied in each case shall be either (a) 50 psi in excess of the normal maximum working pressure based on the elevation of the highest point in the piping assembly or system under test, or (b) 1.5 times the maximum pressure, whichever is the greatest.

The Contractor shall provide all necessary piping connections between the pipe line or piping and the nearest available source of test water, testing pumping equipment, pressure gauge, and other equipment, materials, and facilities necessary for the required tests. The Owner will furnish all water necessary for filling the lines and for making the required tests.

All pipe, fittings, valves, pipe joints, and other materials which are found to be defective shall be removed immediately and replaced with new and acceptable material, by and at the expense of the Contractor.

4-16. DISINFECTING WATER MAINS. Disinfection of lines, as required by the rules and regulations of the South Carolina Department of Health and Environmental Control and in conformity with the requirements of "A Procedure for Disinfecting Water Mains" prepared and approved by the AWWA (Designated C-651), will be performed by the Contractor, with sampling and sample testing performed by the Owner.

4-16.01. In general, one approved method referred to as "continuous feed method" is as follows:

- a. Before being placed in service, all new mains shall be thoroughly flushed then chlorinated with not less than twenty-five (25) milligrams per liter of available chlorine.
- b. Water from the existing distribution system or other source of supply shall be controlled so as to flow slowly into the newly laid pipeline during the application of chlorine.
- c. The solution shall be retained in the pipeline for not less than twenty-four (24) hours and then flushed thoroughly with potable water of satisfactory bacteriological quality before starting the sampling program.

4-16.02. The contractor or owner shall collect a minimum of two (2) samples from each sampling site for total coliform analysis. The number of sites depends on the amount of new construction but must include all dead-end lines, be representative of the water in the newly constructed mains, and

shall be collected a minimum of every 1,200 linear feet.

4-16.03. Prior to sampling, the chlorine residual must be reduced to normal system residual levels or be non-detectable in those systems not chlorinating.

4-16.04. These samples must be collected at least twenty-four (24) hours apart and must show the water line to be absent of total coliform bacteria.

4-16.05. The chlorine residual must also be measured and reported.

4-16.06. If the membrane filter method of analysis is used for the coliform analysis, non-coliform growth must also be reported.

4-16.07. If the non-coliform growth is greater than eighty (80) colonies per one hundred (100) milliliters, the sample result is invalid and must be repeated.

4-16.08. All samples must be analyzed by a State certified laboratory.

4-17. BLOW-OFFS - for installation guidelines see Figure 4 – 2-Inch Blow-Off.

- a. Blow-offs should be located in a box or other structure to facilitate proper use. The orifice should be provided on the fixed piping, in the valve box.
- b. Blow-offs should not be directed towards roads or so that the water will flow into creeks, etc. at stream crossings direct away from streams, over ground.
- c. Orifice sized as follows:

<u>Pipe Diameter</u>	<u>Minimum Flow Required</u>	<u>Orifice Size</u>
2 inch	25 gpm	0.75 inch
2.5 inch	40 gpm	1 inch
3 inch	60 gpm	1.25 inch
4 inch	100 gpm	1.5 inch
6 inch	220 gpm	2 inch
8 inch	400 gpm	2.5 inch
10 inch	612 gpm	Fire Hydrant
12 inch	882 gpm	Fire Hydrant
16 inch	1,570 gpm	Special Blow-off

4-18. AIR RELEASE VALVES - The open end of an air release pipe from automatic valves or from a manually operated valve shall be extended to the top of the pit and provided with a screened downward facing elbow. For installation guidelines see Figure 5 - Air Release Valve.

End of Section

SECTION 5

MATERIAL SPECIFICATIONS

5-1. SCOPE. This specification covers materials to be used for pipe, fittings, gate valves, fire hydrants, and valve boxes for underground water main and water service line installations.

5-2. GENERAL REQUIREMENTS. All materials listed in this specification shall be made in the United States of America.

5-3. PIPE.

5-3.01. Ductile Iron Pipe - Manufactured and tested in accordance with ANSI A21.51, Minimum Pressure Class 350, except 16-inch and larger pipe shall be pressure class 250. Cement lining per ANSI A21.4. Push-on joints per ANSI A21.11, except gaskets shall be synthetic rubber.

5-3.02. Galvanized Steel Pipe - Standard weight with threaded and coupled joints meeting the requirement of AWWA C200.

5-3.03. PEX Pipe – 3/4-inch or 1-inch CTS, rated 250 psi with 12 gauge tracer wire. Provide additional wire as needed to connect to adjacent metal piping or valves.

5-4. FITTINGS.

5-4.01. Compact Ductile Iron Fittings – 4-inch through 12-inch fittings shall be made from Ductile Iron Grade 70-50-05 per ANSI A21.53. Fittings and accessories shall be mechanical or push-on joint per ANSI A21.10 and A21.11. Wall Thickness shall have a Pressure Rating of 350 psi. Exterior bituminous coating per ANSI A21.10 and A21.11, Cement lining per ANSI A21.4.

5-4.02. Ductile Iron Fittings – 3-inch through 48-inch. All ductile iron fittings shall be manufactured and tested per ANSI A21.10. The iron shall be Grade 70-50-05 for ductile iron fittings. Metal thickness shall conform to AWWA C100, Class D. Mechanical or push-on joints shall comply with ANSI A21.11.

5-4.03. Galvanized Iron Fittings. All 2-inch fittings shall be standard weight malleable galvanized iron with standard iron pipe thread.

5-4.04. PEX Fittings. Fittings for PEX pipe shall be brass compression fittings as manufactured by Ford or Mueller.

5-5. RESTRAINED JOINTS.

5-5.01. “Megalugs.” – As an alternative to standard restrained joints, EBAA Iron “Megalugs” Series 1100 or 1700, without substitute, may be used for 4-inch through 20-inch ductile iron pipe. The locations for “Megalugs” shall be acceptable to Engineer.

5-5.02. Field Lock Gaskets – As an alternative to standard restrained joints, field lock gaskets, may be used for 4-inch through 20-inch ductile iron pipe. The locations for field lock gaskets shall be acceptable to Engineer.

5-6. GATE VALVES

5-6.01. Iron-Body Resilient-Seat (IBRS) Gate Valves - sizes 2-inch – 12-inch inclusive. Order Specification: Resilient Wedge, Non-Rising Stem (NRS), Rated at 200 psig WWP, O-Ring Seals, Standard 2-inch Square Wrench Nut, and conforming to ANSI/AWWA C509. Check with Engineering for direction of opening.

5-6.02. APPROVED IBRS GATE VALVES, SIZES 4-inch – 12-inch, INCLUSIVE:

<u>NAME</u>	<u>CATALOG #, MJ ENDS</u>
1. American Flow Control	Series 2500
2. Mueller	Series 2360
3. U. S. Pipe	A-USPO

Check with Engineering for specifications on all valves over 12-inch size.

5-6.03. APPROVED IBRS GATE VALVES, SIZE 2-inch: Threaded x Threaded Ends (NPT), with Standard 2-inch Square Wrench Nut, Open Left, conforming to AWWA C509, rated at 200 psi WWP.

<u>NAME</u>	<u>CATALOG #</u>
1. American Flow Control	Series 2500
2. Mueller	Series 2360

5-6.04. APPROVED BRONZE VALVES, SIZE 2-inch: All 2-inch bronze gate valves shall be solid wedge, inside screw, non-rising spindle, rated 125 psi SWP or 200 psi WOG, Open Left, threaded ends (NPT), with standard markings and complying with Fed. Spec. WW-V-54.

<u>NAME</u>	<u>CATALOG #</u>
1. CRANE COMPANY (Canadian manufacture only)	438

5-7. FIRE HYDRANTS - All fire hydrants shall be 4-1/2-inch minimum nominal valve opening, National Standard Nozzle Threads and Operating Details, Two 2-1/2-inch nozzles and One 4-1/2-inch nozzle, 6-inch M.J. Inlet Connection, depth of bury to suit field conditions, painted highway safety yellow, breakable ground flange and conforming to AWWA C502. Check with Engineering for direction of opening. See Typical Hydrant Installation detail.

5-7.01. APPROVED FIRE HYDRANTS:

<u>NAME</u>	<u>CATALOG #</u>
1. American-Darling	B-62-B (5-1/4-inch Valve Opening)
2. American-Darling	MK 73-5
3. U. S. Pipe	Sentinel 250 (4-1/2-inch or 5-1/4-inch Valve Opening)
4. Mueller Super Centurion 250	A-421 (4-1/2-inch Valve Opening)
5. Mueller Super Centurion 250	A-423 (5-1/4-inch Valve Opening)
6. M&H	Model 129 – 3 Way (4-1/2-inch or 5-1/4-inch Valve Opening)

5-8. AIR RELEASE VALVES. Individual air release valves shall be provided and installed as indicated on the drawings. Each valve assembly shall be installed complete with appurtenant piping and valves as indicated on the drawings.

Individual air release valves shall have a 1-inch inlet connection unless otherwise noted on the drawings, and shall be GA Industries "Figure 920H," Multiplex "Crispin Type N," or APCO "200A." A gate valve shall be provided in the piping to each air release valve.

The valves shall be designed for water working pressure of 300 psi and shall have stainless steel floats. All working parts shall be constructed of brass, stainless steel, or other corrosion-resistant materials.

The exhaust from each valve shall be piped to a suitable disposal point.

5-9. VALVE BOXES - All valve boxes shall be Greenville Water Standard (Opelika 107-2).

End of Section

L:\Engg\DWG-SUPPORT\Details\PipeEmbedments.dwg, 10/30/2013 11:29:08 AM

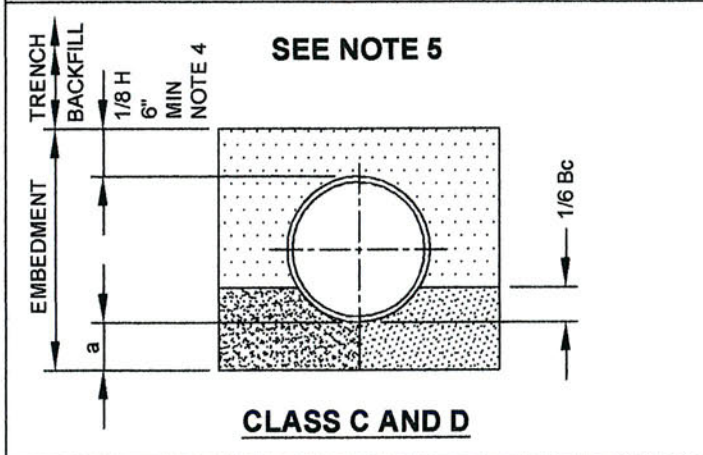
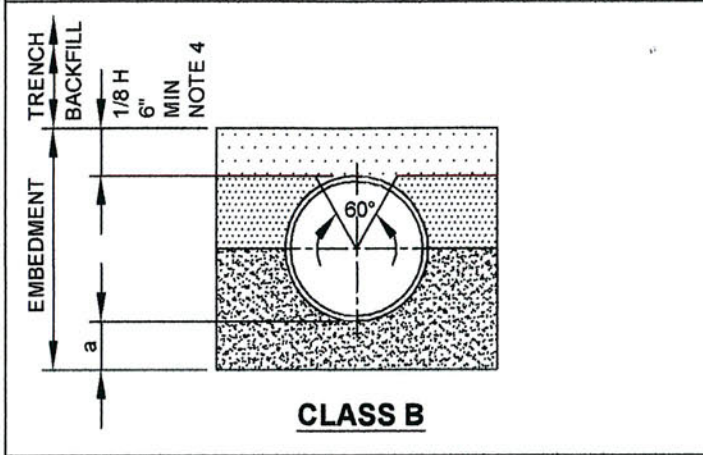
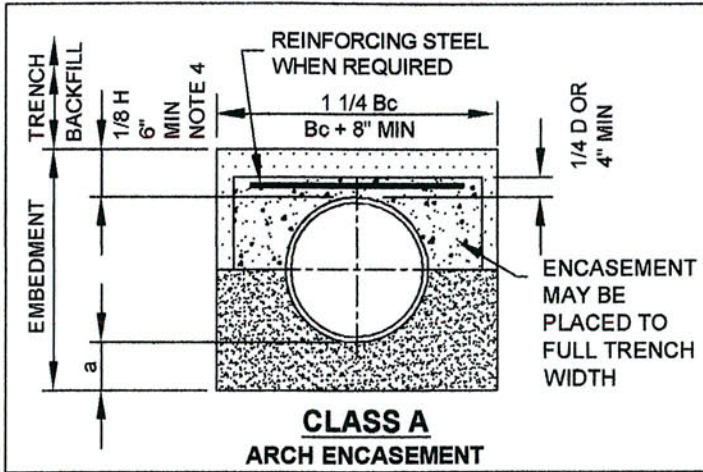

TABLE OF EMBEDMENT DEPTH BELOW PIPE





D	a MIN SOIL	a MIN ROCK
	ln	ln
27" & SMALLER	3	6
30" TO 60"	4	9
64" & LARGER	6	12

NOTES:

1. GRANULAR EMBEDMENT MATERIAL SHALL BE # 57 WASHED STONE OR PEA GRAVEL. EMBEDMENT MATERIAL SHALL BE PLACED IN LAYERS NOT MORE THAN 6" DEEP AND COMPACTED AS SPECIFIED.
2. HAND PLACED EMBEDMENT SHALL BE FINELY DIVIDED MATERIAL FREE FROM DEBRIS AND STONES.
3. COMPACTED EMBEDMENT SHALL BE FINELY DIVIDED JOB EXCAVATED MATERIAL FREE FROM DEBRIS, ORGANIC MATERIAL AND STONES, PLACED IN UNIFORM LAYERS NOT MORE THAN 8" THICK, AND COMPACTED TO 95% MAXIMUM DENSITY. GRANULAR EMBEDMENT MAY BE SUBSTITUTED FOR ALL OR PART OF THE COMPACTED EMBEDMENT.
4. EMBEDMENT ABOVE THE TOP OF THE PIPE SHALL BE AN UNCOMPACTED LAYER FOR ALL INSTALLATIONS.
5. FOR CLASS C USE GRANULAR EMBEDMENT. FOR CLASS D USE COMPACTED EMBEDMENT.
6. TRENCH OUTLINES DO NOT INDICATE ACTUAL TRENCH EXCAVATION SHAPE, SOIL CONDITIONS, OR PRESENCE OF SHEETING LEFT IN PLACE. EMBEDMENT MATERIAL SHALL EXTEND THE FULL WIDTH OF THE ACTUAL TRENCH EXCAVATION.

LEGEND

- Bc OUTSIDE DIAMETER OF PIPE
- H COVER ABOVE TOP OF PIPE
- D NOMINAL PIPE SIZE
- a EMBEDMENT BELOW PIPE (SEE TABLE)

-  HAND PLACED EMBEDMENT
-  COMPACTED EMBEDMENT
-  GRANULAR EMBEDMENT
-  CONCRETE

PIPE EMBEDMENTS



MINIMUM DIMENSIONS FOR CONCRETE BLOCKING

BEND	SIZE	A	B	C	D
11 1/4°	6"	1'-0"	2'-0"	4"	1'-0"
	8"	1'-0"	2'-0"	5"	1'-0"
	10"	1'-0"	2'-0"	6"	1'-0"
	12"	1'-0"	2'-0"	7"	1'-0"
	14"	2'-0"	2'-0"	11"	1'-6"
	16"	1'-0"	2'-0"	1'-0"	2'-0"
	20"	2'-0"	3'-0"	1'-3"	2'-0"
24"	2'-0"	3'-0"	1'-6"	3'-0"	
22 1/2°	6"	1'-0"	2'-0"	6"	1'-0"
	8"	1'-0"	2'-0"	7"	1'-0"
	10"	1'-0"	2'-0"	8"	1'-6"
	12"	1'-0"	2'-0"	10"	2'-0"
	14"	2'-0"	3'-0"	11"	2'-0"
	16"	2'-0"	4'-0"	1'-0"	2'-0"
	20"	2'-0"	4'-0"	1'-3"	3'-0"
24"	3'-0"	4'-6"	1'-6"	4'-0"	
45°	6"	1'-0"	2'-0"	6"	1'-0"
	8"	1'-0"	2'-0"	7"	2'-0"
	10"	2'-0"	3'-0"	9"	2'-0"
	12"	2'-0"	3'-0"	11"	3'-0"
	14"	2'-0"	4'-0"	11"	3'-0"
	16"	3'-0"	5'-0"	1'-0"	3'-0"
	20"	4'-0"	6'-0"	1'-3"	4'-0"
24"	4'-0"	7'-0"	1'-6"	5'-0"	
90°	6"	1'-0"	2'-0"	1'-0"	2'-0"
	8"	2'-0"	3'-0"	1'-2"	2'-6"
	10"	2'-6"	3'-9"	1'-6"	3'-0"
	12"	2'-0"	4'-0"	2'-0"	4'-0"
	14"	3'-0"	5'-0"	2'-0"	4'-6"
	16"	4'-0"	6'-0"	2'-2"	4'-9"
	20"	4'-0"	7'-0"	2'-8"	6'-4"
24"	5'-0"	8'-0"	3'-4"	8'-0"	
TEES & PLUGS	6"	1'-0"	2'-0"	10"	1'-6"
	8"	1'-9"	2'-6"	1'-1"	2'-0"
	10"	2'-0"	4'-0"	1'-3"	2'-0"
	12"	2'-6"	3'-9"	1'-7"	3'-0"
	14"	3'-0"	5'-0"	2'-0"	3'-0"
	16"	3'-0"	5'-0"	2'-2"	4'-0"
	20"	4'-0"	6'-0"	2'-8"	5'-0"
24"	6'-0"	9'-0"	3'-4"	5'-0"	

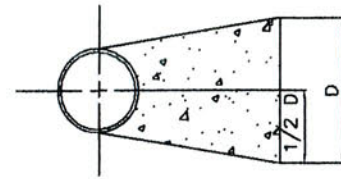
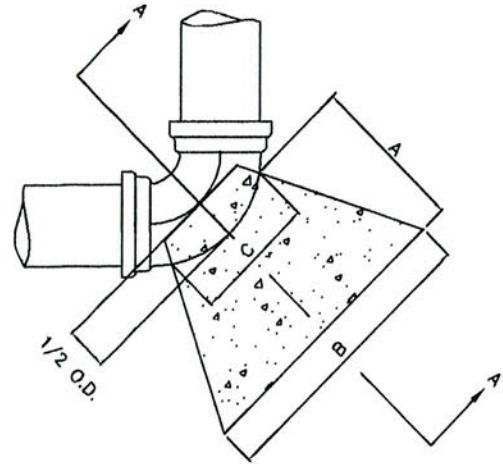

SECTION A-A

NOTE

SOIL CONDITIONS SHALL BE VERIFIED BY G. W. FIELD ENGINEER PRIOR TO DESIGN.

DESIGN DATA:

- DIMENSIONS OF THRUST BLOCK IN FEET BASED ON 2000 POUNDS PER SQUARE FOOT SOIL BEARING PRESSURE AND 200 POUNDS PER SQUARE INCH TEST PRESSURE
- CONCRETE SHALL HAVE A COMPRESSIVE STRENGTH OF 3000 PSI AT 28 DAYS. HIGH EARLY CONCRETE SHALL BE USED.



GreenvilleWater

TYPICAL HORIZONTAL THRUST BLOCK

REVISED: 08/02/2013

L:\ENGG\DWG-SUPPORT\DETAILS\THRUSTBLOCK.DWG

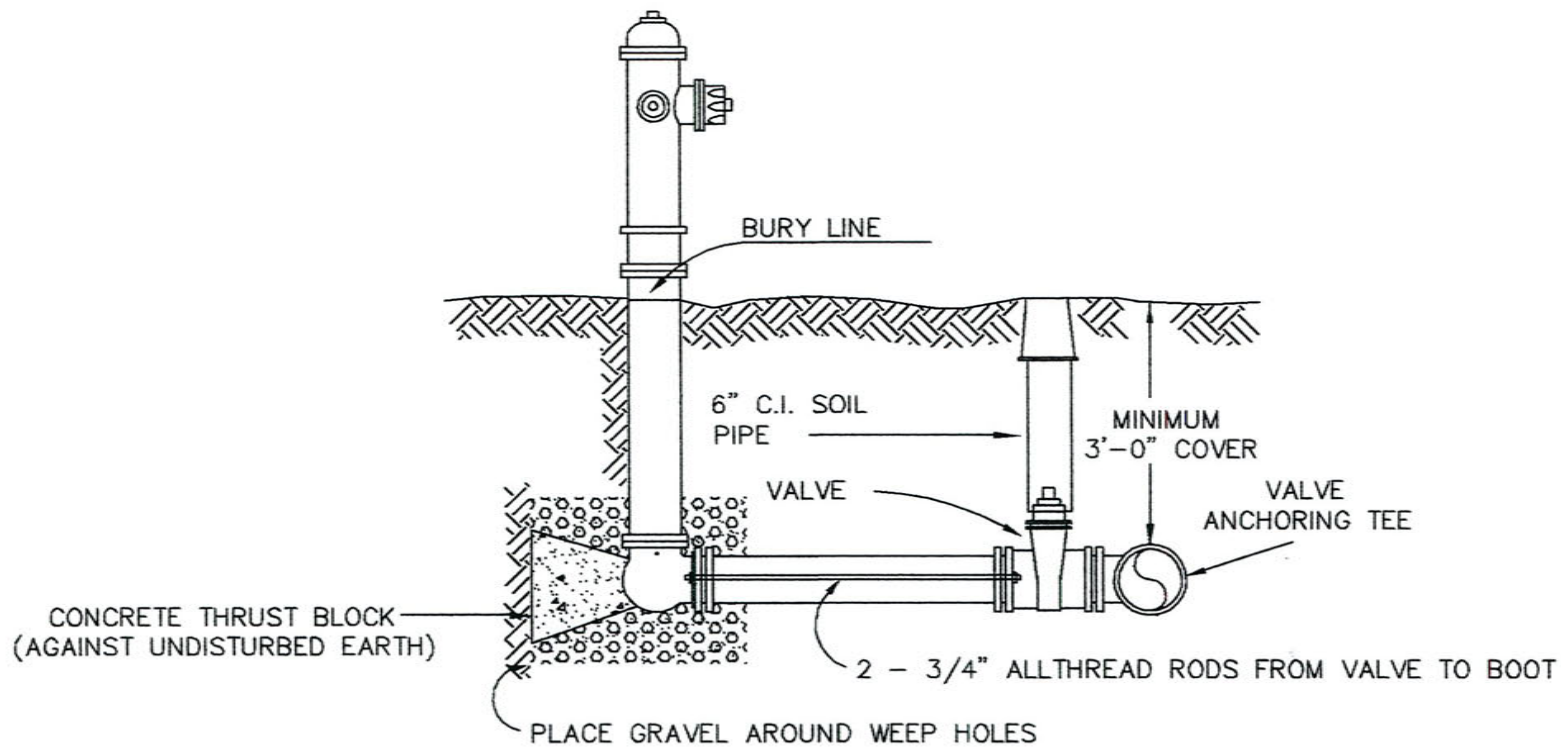

NOTES:

- 1) FIRE HYDRANT TO BE INSTALLED PLUMB.
- 2) FIRE HYDRANT TO BE 3-WAY WITH DEPTH OF BURY TO BE DETERMINED BY FIELD CONDITIONS.
- 3) HYDRANT LEAD TO BE PRESSURE CLASS 350 DUCTILE IRON.
- 4) WHEN FIRE HYDRANT RESTRAINT BY RODDING NECESSARY, TWO 3/4" ϕ ALLTHREAD RODS REQUIRED AS A MINIMUM.



GreenvilleWater

TYPICAL HYDRANT INSTALLATION

REVISED: 8/30/2013

L:\ENGG\DWG-SUPPORT\DETAILS\HYDINSTDET.DWG

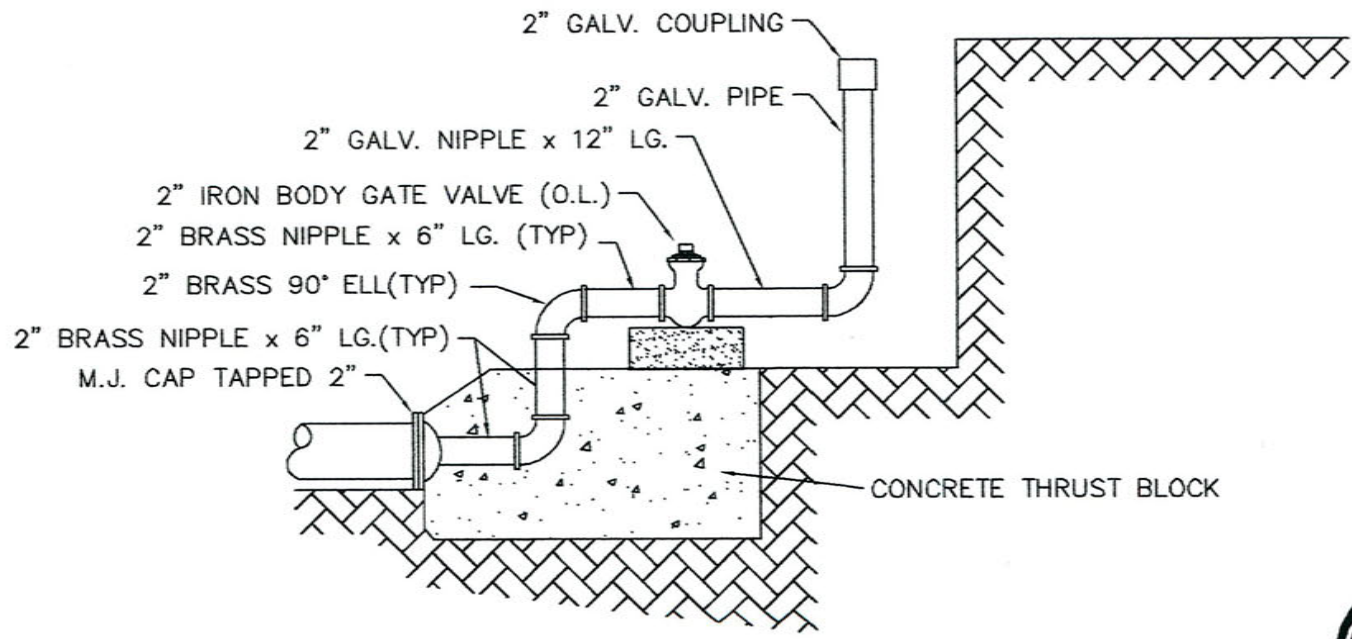

NOTE: PRIOR TO BACKFILL, 6" C.I. SOIL PIPE AND VALVE BOX WILL BE PLACED OVER VALVE AND VERTICAL 2" PIPING (BOX ONLY).



GreenvilleWater

2" BLOW-OFF

REVISED: 08/30/2013
 L:\ENGG\DWG-SUPPORT\DETAILS\BLOWOFF.DWG

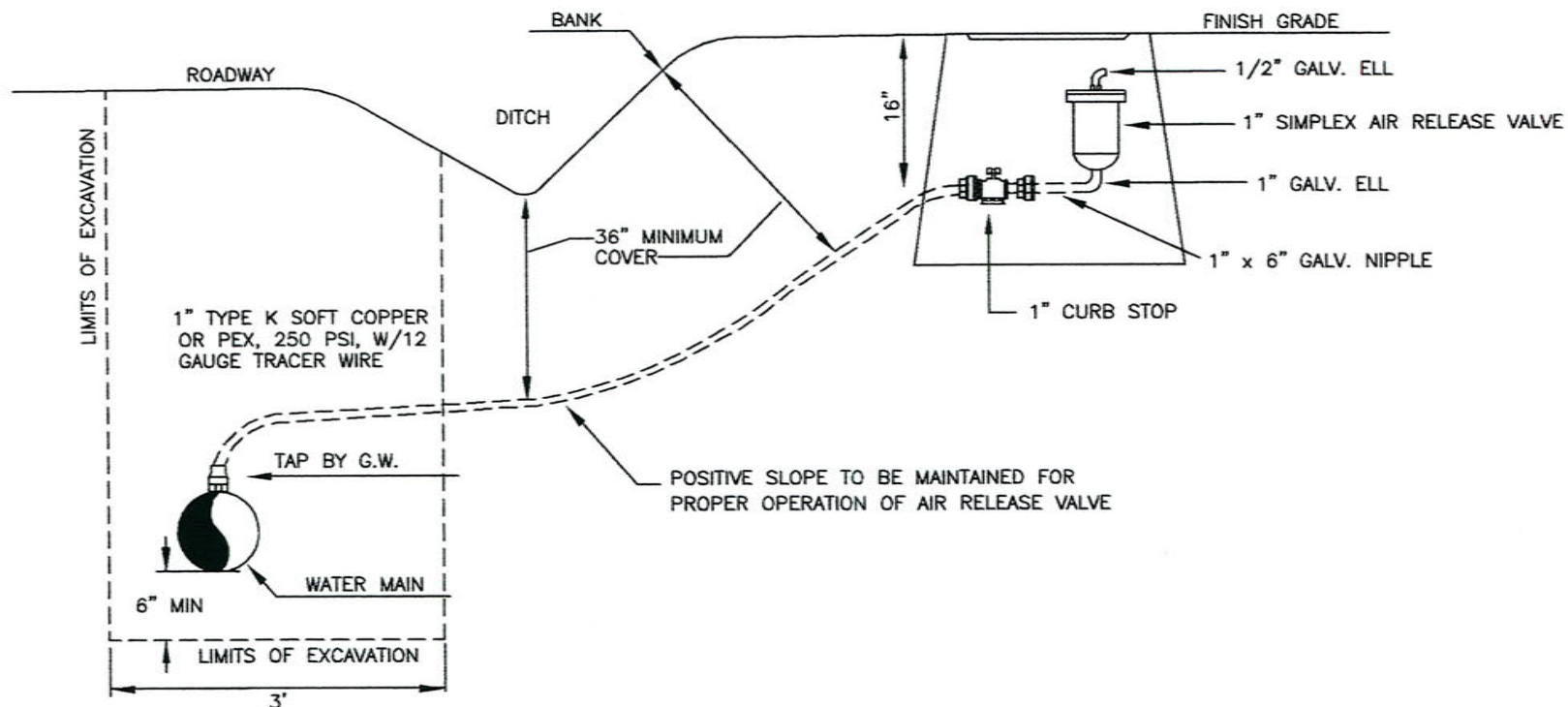

NOTE:

REQUIRED AS DIRECTED ON ALL WATER MAINS 10" AND LARGER.
 ALL EXCAVATING TO BE DONE BY CONTRACTOR.
 APPROXIMATE SIZE OF HOLE WHERE TAP IS MADE IS 3' X 5' (6" BEHIND AND UNDER MAIN WITH REMAINDER OF EXCAVATION ON TAP SIDE OF MAIN)
 PLACE FOR AIR RELEASE BOX 3' X 3' X 21" DEEP.
 SERVICE LINE 36" MIN. COVER UNDER ROADSIDE DITCH.
 BOX NOT TO BE PLACED IN DRIVEWAY.
 CONTRACTOR SHOULD CALL G.W. ENGINEERING TO REPORT WHEN READY FOR TAP TO BE MADE AND AIR RELEASE VALVE TO BE SET.



GreenvilleWater

AIR RELEASE VALVE

(TYPICAL DETAIL)

REVISED: 08/02/2013

L:\ENGG\DWG-SUPPORT\AIRELEASEVALVE.DWG